

RECOMMEND PCB LAYOUT  
GENERAL TOLERANCE ±0.05

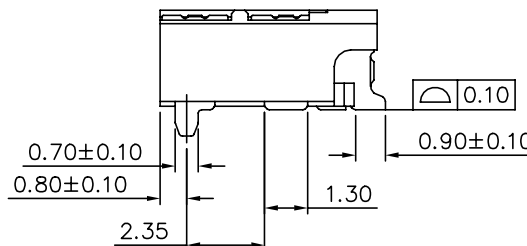
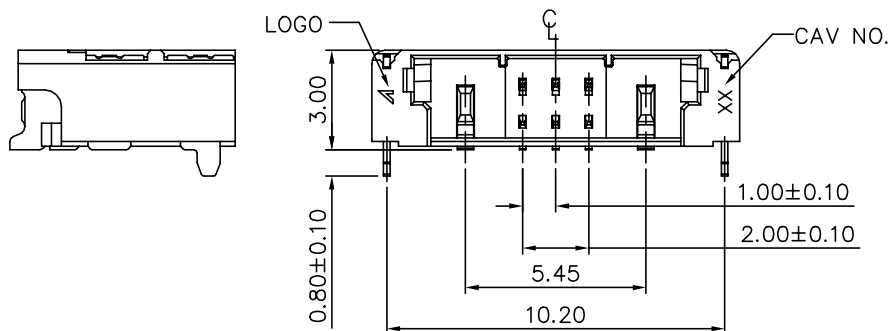

- NOTES:
- MATERIAL:
    - HOUSING: THERMOPLASTIC, HIGH TEMP., UL94V-0; COLOR: BLACK.(PA9T)
    - SIGNAL CONTACT: COPPER ALLOY. (C5191)
    - POWER CONTACT: COPPER ALLOY. (C18140)
    - FITTING NAIL: COPPER ALLOY. (C2680)
  - FINISH:
    - SIGNAL CONTACT:
      - 50u"MIN. NICKEL OVERALL.
      - L: 60u"MIN. PURE TIN ON PLATING AREA.
      - N: 60u"MIN. MATT TIN ON PLATING AREA.
    - POWER CONTACT:
      - 50u"MIN. NICKEL OVERALL.
      - L: 60u"MIN. PURE TIN ON PLATING AREA.
      - N: 60u"MIN. MATT TIN ON PLATING AREA.
    - FITTING NAIL:
      - 50u"MIN. NICKEL OVERALL.
      - L: 60u"MIN. PURE TIN ON PLATING AREA.
      - N: 60u"MIN. MATT TIN ON PLATING AREA.
  - REFLOW SOLDER CAPABLE TO 260°C PER ACES SPEC.
  - SPEC. PLS. REFER TO PS-51373-XXXXX-XXX
  - PACKAGE PLS. REFER TO 51373-XXXXX-XX-TRP

51373-XXX X X -XXX

CKTS	XXX	PACKAGE
005: 3+2 PIN	001	51373-XXXXX-XXX-TRP
PACKAGE		L: PURE TIN
0: TAPE&REEL		N: MATT TIN

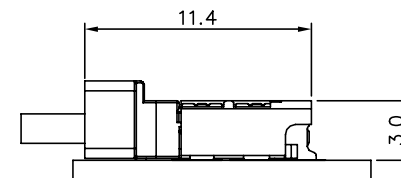

MATING CONN.

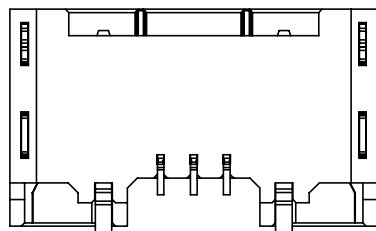

<b>QUALITY SYMBOLS</b> MAJOR Ⓢ CRITICAL Ⓢ <b>GENERAL TOLERANCES (UNLESS SPECIFIED)</b> X. ±0.5 .X ±0.25 .XX ±0.15 .XXX ±0.1 ANGLES ±2°	DRAWN BY	DATE	
	GAOLI	22/06/27	
	CHECKED BY	DATE	<b>TITLE</b> 1.0mm WTB Wafer SMT S/R R/A type
	XUZHUYONG	22/06/27	
	APPROVED BY	DATE	
	XUZHUYONG	22/06/27	
	UNITS	SIZE	RFQ NO.
	mm	A4	N/A
	SCALE	REV	DWG NO.
	4:1	B	51373-XXXXX-XXX
	SHEET NO.		
	1 OF 1		